

## Fronius Symo 3 - 8,2 kW

EN

Installation instructions

Grid-connected inverter





# Contents

Installation location and position.....	4
Explanation of safety notices.....	4
Safety .....	4
Proper use/intended purpose.....	5
Choosing the location of the inverter.....	6
Explanation of symbols - installation position.....	7
General comments regarding inverter installation location .....	8
Attaching the Mounting Bracket.....	9
Safety .....	9
Selecting wall plugs and screws .....	9
Recommended screws.....	9
Opening the inverter.....	9
Fitting the mounting bracket to a wall.....	10
Installing the mounting bracket on a mast or beam.....	11
Fitting the mounting bracket to metal supports.....	11
Do not warp or deform the mounting bracket.....	12
Connecting the inverter to the public grid (AC side).....	13
Safety .....	13
Monitoring the grid.....	13
Type of AC cable.....	13
Preparing the aluminium cables for connection.....	13
AC terminals.....	14
Cross section of the AC cable.....	14
Connecting the inverter to the public grid (AC).....	15
Maximum fuse rating on alternating current side.....	15
Notes regarding inverters with single and multiple MPP trackers .....	17
Inverter with single MPP tracker.....	17
Inverter with multiple MPP trackers.....	17
Connecting solar module strings to the inverter .....	19
Safety .....	19
General comments regarding solar modules .....	20
DC terminals.....	20
Connecting aluminium cables.....	20
Solar module strings - checking the polarity and voltage .....	21
Connecting solar module strings to the inverter (DC).....	21
Data communication.....	25
Routing data communication cables .....	25
Installing the Datamanager in the inverter.....	25
Attaching the inverter to the mounting bracket.....	28
Attaching the inverter to the mounting bracket .....	28
Starting for the first time.....	30
Starting the inverter for the first time .....	30
Notes regarding software updates.....	33
Notes regarding software updates.....	33
USB Stick as a Data Logger and for Updating Inverter Software.....	34
USB flash drive as a datalogger .....	34
Data on the USB flash drive .....	34
Data volume and storage capacity .....	35
Buffer memory.....	36
Suitable USB flash drives.....	36
USB stick for updating the inverter software.....	37
Removing the USB flash drive .....	37
Notes regarding maintenance.....	38
Maintenance.....	38
Cleaning.....	38
Australian cable protection hoses.....	39
Tightly sealing the protection hoses .....	39
Seal conduits.....	39
Serial Number Sticker for Customer Use.....	40
Serial number sticker for customer use .....	40

# Installation location and position

---

## Explanation of safety notices

### **DANGER!**

Indicates **immediate danger**.

- ▶ If not avoided, death or serious injury will result.
- 

### **WARNING!**

Indicates a **potentially hazardous situation**.

- ▶ If not avoided, death or serious injury may result.
- 

### **CAUTION!**

Indicates a **situation where damage or injury could occur**.

- ▶ If not avoided, minor injury and/or damage to property may result.
- 

### **NOTE!**

Indicates a **risk of flawed results and possible damage to the equipment**.

---

## Safety

### **WARNING!**

**Danger due to incorrect operation and incorrectly performed work.**

This can result in serious injury and damage to property.

- ▶ Only qualified personnel are authorised to commission your inverter and only within the scope of the respective technical regulations.
  - ▶ Read the Installation and Operating Instructions before installing and commissioning the equipment.
- 

### **WARNING!**

**Danger due to work that has been carried out incorrectly.**

This may result in serious injury and damage to property.

- ▶ Surge protective devices must only ever be installed and connected by a qualified electrical installation engineer!
  - ▶ Follow the safety rules.
  - ▶ Ensure that both the AC side and the DC side of the inverter are de-energised before carrying out any installation and connection work.
-

## Fire prevention

### CAUTION!

#### **Danger due to poor or unprofessional installation.**

This may result in damage to inverters and other live photovoltaic system components. Poor or unprofessional installation can cause overheating of cables and terminal connections and result in arcs. These can cause heat damage, which in turn may lead to fires.

Observe the following when connecting AC and DC cables:

- ▶ Tighten all terminals to the torque specified in the operating instructions
  - ▶ Tighten all grounding terminals (PE / GND), including free ones, to the torque specified in the operating instructions
  - ▶ Do not overload cables
  - ▶ Check cables for damage and verify that they are laid correctly
  - ▶ Take note of the safety instructions, Operating Instructions and any local connection regulations
- 
- ▶ Using fastening screws, always screw the inverter firmly to the mounting bracket to the torque specified in the Operating Instructions.
  - ▶ Ensure that the fastening screws are tight before starting the inverter!

**Note!** Fronius will not accept any costs associated with production downtimes, installer costs, etc., that may arise as the result of a detected arc and its consequences. Fronius accepts no liability for fires that can occur despite the presence of the integrated arc detection/extinguishing system (e.g. fires caused by a parallel arc).

**Note!** After an arc has been detected, the entire photovoltaic system must be checked for possible damage before resetting the inverter.

Observe the manufacturer's connection, installation and operating instructions at all times. To reduce the hazard potential to a minimum, perform all installation and connection work carefully according to the instructions and regulations. Refer to the device Installation Instructions for the tightening torques to be used at the relevant terminal connections.

### **Proper use/intended purpose**

The inverter is intended exclusively to convert direct current from solar modules into alternating current and to feed this into the public grid.

Utilisation not in accordance with the intended purpose comprises:

- Any use above and beyond this purpose
- Making any modifications to the inverter that have not been expressly approved by Fronius
- the installation of components that are not distributed or expressly approved by Fronius.

Fronius shall not be liable for any damage resulting from such action. No warranty claims will be entertained.

Proper use also includes:

- Carefully reading and obeying all the instructions and all the safety and danger notices in the Operating Instructions and Installation Instructions
- Performing all stipulated maintenance work
- Installation as specified in the Installation Instructions

When designing the photovoltaic system, ensure that all components are operated within their permitted operating ranges at all times.

Observe all the measures recommended by the solar module manufacturer to ensure that the solar module retains its properties in the long term.

Obey the regulations of the power supply company regarding connection methods and energy fed into the grid.

### Choosing the location of the inverter

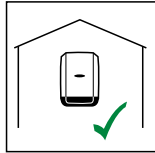

The inverter is suitable for indoor installation.

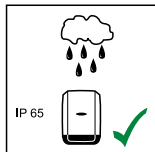

The inverter is suitable for outdoor installation.

Because of its IP 65 protection class, the inverter is resistant to water jets from any direction and can also be used in damp environments.

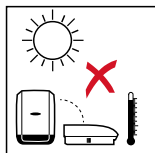

In order to minimise the heating up of the inverter, do not expose it to direct insolation. Install the inverter in a protected location, e.g. in the vicinity of the solar modules or beneath the eaves.

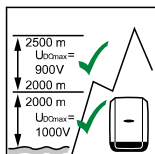
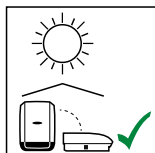

$U_{DCmax}$  at an altitude of:  
 0 to 2000 m = 1000 V  
 2000 to 2500 m = 900 V  
 2500 to 3000 m = 815 V  
 3000 to 3400 m = 750 V

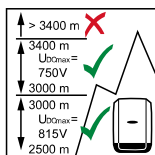

**IMPORTANT!** The inverter must not be installed or used at altitudes above 3400 m.

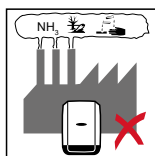

Do not install the inverter in:

- Areas where ammonia, corrosive vapours, acids or salts are present (e.g. fertiliser stores, ventilation openings from cattle sheds, chemical plants, tanneries, etc.)

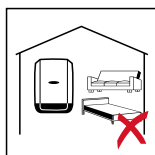

During certain operating phases the inverter may produce a slight noise. For this reason it should not be installed in an occupied living area.

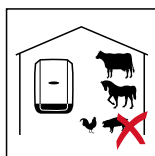

Do not install the inverter in:

- Places where there is an increased risk of damage from farm animals (horses, cattle, sheep, pigs, etc.)
- Stables or adjoining areas
- Storage areas for hay, straw, chaff, animal feed, fertilisers, etc.



All inverters are designed to be dust-tight. However, in areas with a heavy build-up of dust, the thermal efficiency may still be impaired by dust forming on the cooling surfaces. Regular cleaning is necessary in such situations. We therefore recommend not installing the inverter in areas and environments with high dust accumulation.



Do not install the inverter in:

- Greenhouses
- Storage or processing areas for fruit, vegetables or viticulture products
- Areas used in the preparation of grain, green fodder or animal feeds

**Explanation of symbols - installation position**



The inverter is suitable for vertical installation on a vertical wall or column.



The inverter is suitable for a horizontal installation position.

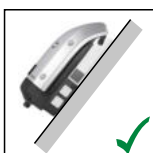

The inverter is suitable for installation on a sloping surface.

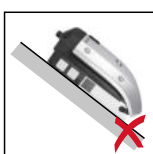

Do not install the inverter on a sloping surface with its connection sockets at the top.



Do not install the inverter at an angle on a vertical wall or column.



Do not install the inverter horizontally on a vertical wall or pillar.



Do not install the inverter on a vertical wall or pillar with its connection sockets facing upwards.

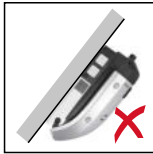

Do not install the inverter overhanging with the connection sockets at the top.



Do not install the inverter overhanging with the connection sockets at the bottom.



Do not install the inverter on the ceiling.

### General comments regarding inverter installation location

Please note the following criteria when choosing a location for the inverter:

Install only on a solid, non-flammable surface

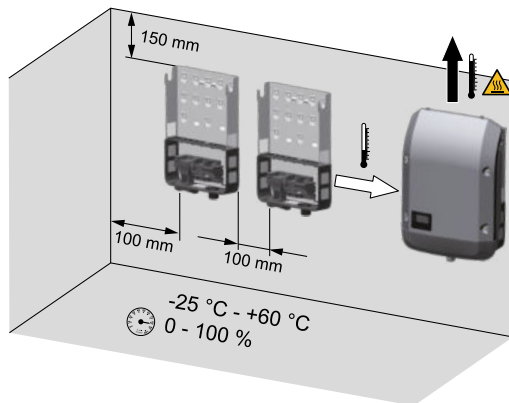

Max. ambient temperatures:  
-25 °C / +60 °C

Relative humidity:  
0-100%

The airflow within the inverter is from the left to the top (cold air taken in from the left, hot air dissipated out of the top). The exhaust air can reach a temperature of 70 °C.

If the inverter is installed in a switch cabinet or a similar sealed area, then forced-air ventilation must be provided to ensure adequate heat dissipation.

If the inverter is to be installed on the outer wall of a cattle shed, maintain a minimum all-round clearance of 2 m between the inverter and all ventilation and other openings in the building.

The installation location must not be exposed to ammonia, corrosive vapours, salts or acids.



# Attaching the Mounting Bracket

## Safety

### **WARNING!**

#### **Danger due to residual voltage in capacitors.**

This may result in an electric shock.

- ▶ Wait for the capacitors to discharge. The discharge time is five minutes.

### **CAUTION!**

#### **Danger due to dirt or water on the terminals and contacts of the inverter's connection area.**

This may result in damage to the inverter.

- ▶ When drilling, ensure that terminals and contacts in the connection area do not become dirty or wet.
- ▶ The mounting bracket without a power stage set does not conform to the protection class of the inverter as a whole, and therefore must not be installed without a power stage set.
- ▶ The mounting bracket should be protected from dirt and moisture during installation.

Note! Degree of protection IP 65 is only applicable if

- the inverter is placed in the mounting bracket and permanently attached using screws ,
- the cover for the data communication area is permanently attached to the inverter with screws.

Degree of protection IP 20 applies to the mounting bracket with no inverter and the venting duct.

## Selecting wall plugs and screws

**Important!** Different fixings may be required to fit the mounting bracket depending on the type of underlying surface. Fixings are therefore not included in the scope of supply of the inverter. The installer is responsible for selecting the right type of fixing.

## Recommended screws

To install the inverter, the manufacturer recommends the use of steel or aluminium screws with a diameter of 6 - 8 mm.

## Opening the inverter

### **WARNING!**

#### **Danger from inadequate ground conductor connection.**

This can result in serious injury and damage to property.

- ▶ The housing screws provide a suitable ground conductor connection for grounding the housing and must NOT be replaced by any other screws that do not provide a reliable ground conductor connection.

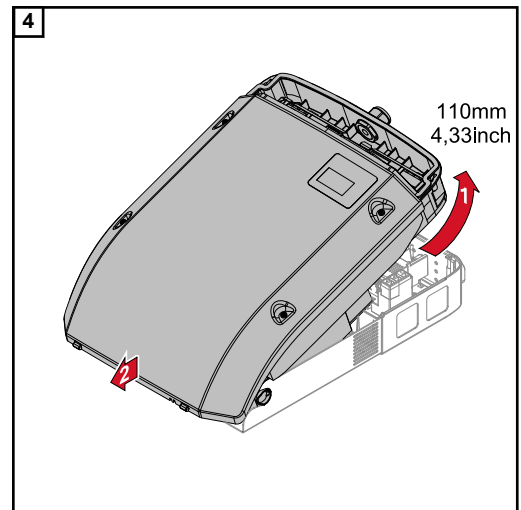
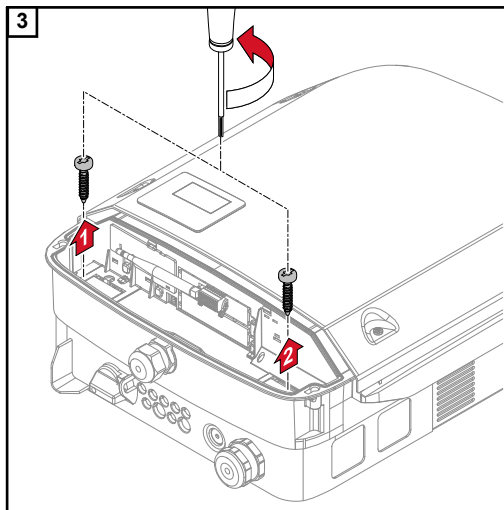
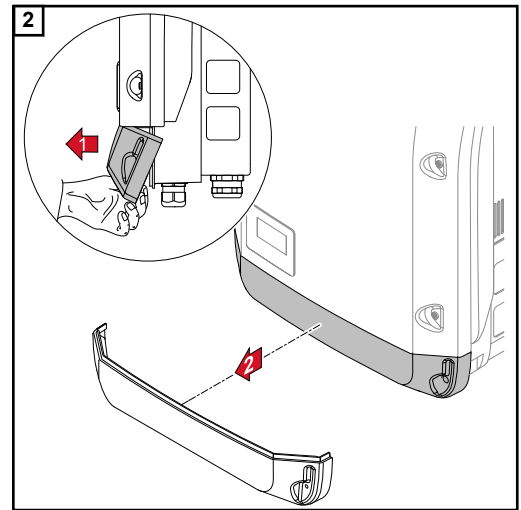
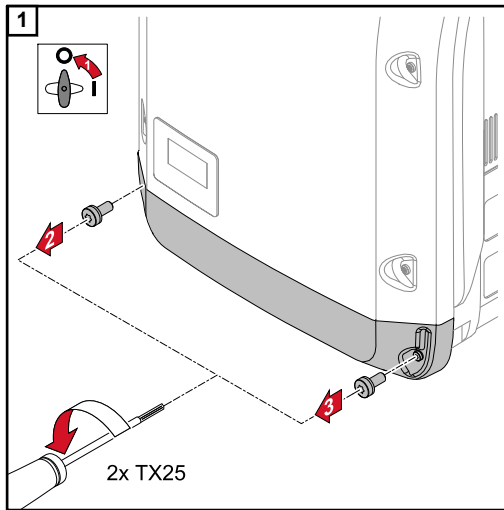

**Fitting the mounting bracket to a wall**

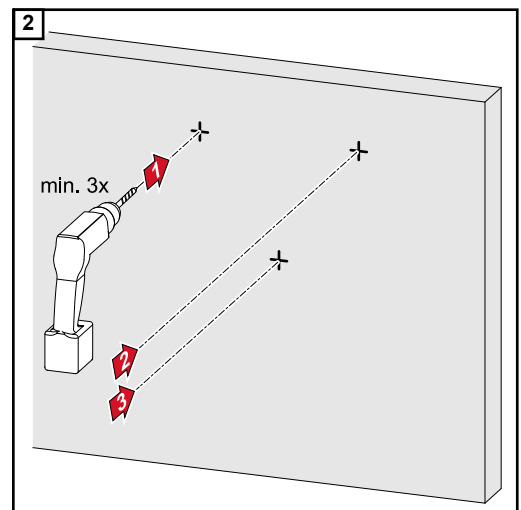
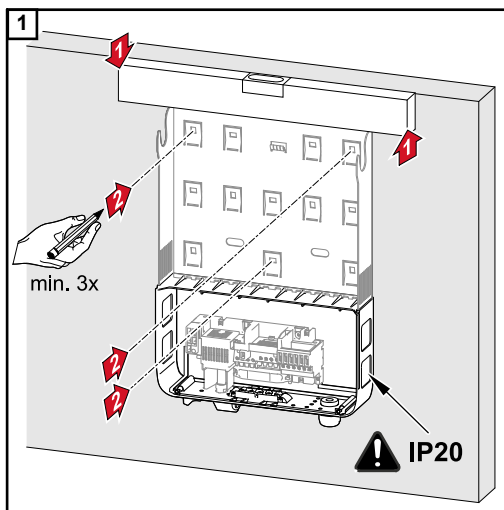

*Tip: Install the inverter so that its display is at eye level*

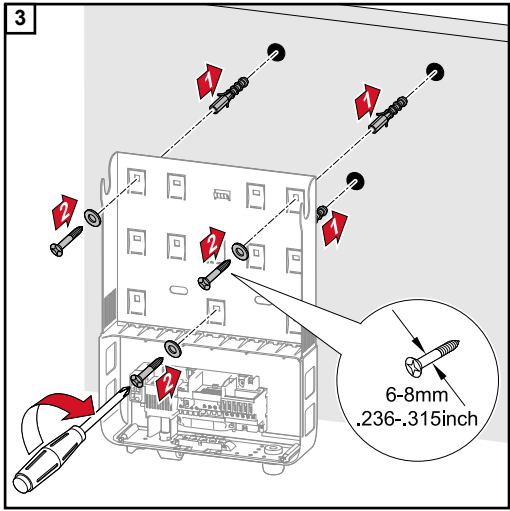

**Note!** When mounting the mounting bracket on the wall, ensure that the mounting bracket does not become warped or deformed.

**Installing the mounting bracket on a mast or beam**

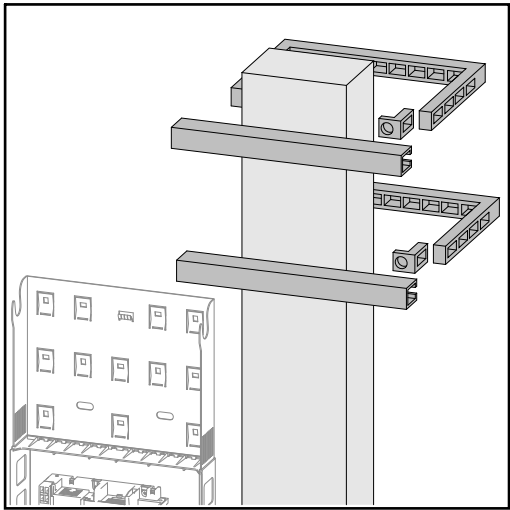

When installing the inverter on a mast or support, Fronius recommends the "Pole Clamp" kit from Rittal GmbH (order no. SZ 2584.000). This kit enables the inverter to be installed on round or rectangular masts with the following diameters:  $\varnothing$  from 40 to 190 mm (round mast),  $\bar{y}$  from 50 to 150 mm (rectangular mast)

**Fitting the mounting bracket to metal supports**

The mounting bracket must be securely screwed to at least four points.

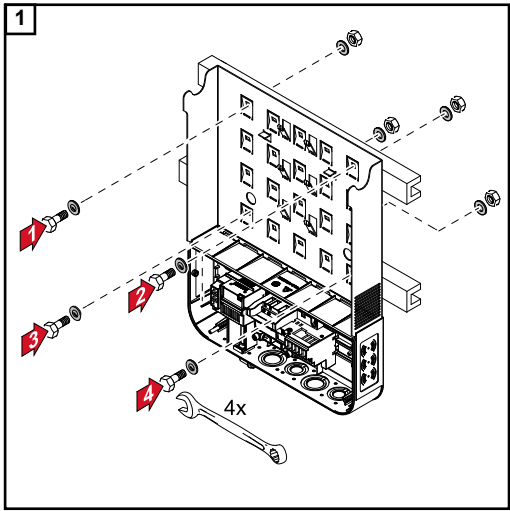

**Do not warp or deform the mounting bracket**

**Note!** When fitting the mounting bracket to the wall, ensure that the mounting bracket does not become warped or deformed.

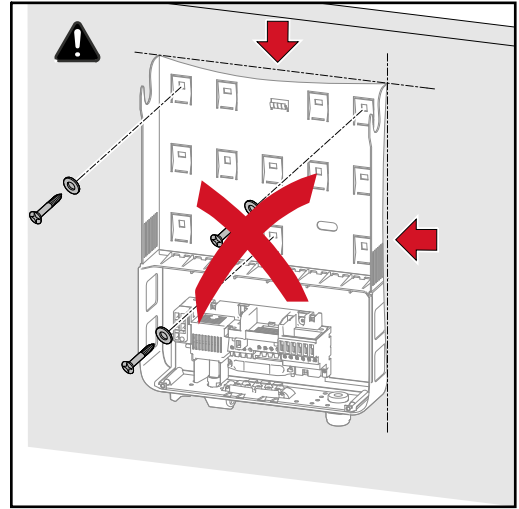
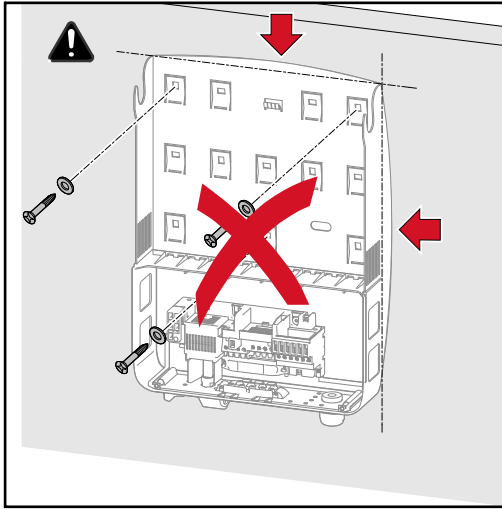

# Connecting the inverter to the public grid (AC side)

## Safety

### **WARNING!**

#### **Danger due to incorrect operation and incorrectly performed work.**

This may result in serious injury and damage to property.

- ▶ Only qualified staff are authorised to commission your inverter and only within the scope of the respective technical regulations.
- ▶ Read the Installation and Operating Instructions before installing and commissioning the equipment.

### **WARNING!**

#### **Danger due to grid voltage and DC voltage from solar modules that are exposed to light.**

This may result in an electric shock.

- ▶ Ensure that both the AC side and the DC side of the inverter are de-energised before carrying out any connection work.
- ▶ Only an authorised electrical engineer is permitted to connect this equipment to the public grid.

### **CAUTION!**

#### **Danger due to incorrectly tightened terminals.**

This may result in heat damage to the inverter, which may lead to fire.

- ▶ When connecting AC and DC cables, ensure that all the terminals are tightened to the specified torque.

## Monitoring the grid

To provide the best possible grid monitoring, the resistance in the leads to the AC-side terminals should be as low as possible.

## Type of AC cable

The following types of AC cable can be connected to the AC terminals of the inverter:

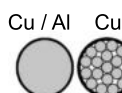

- Copper or aluminium: solid round conductor
- Copper: fine-stranded round conductor, up to conductor class 4

## Preparing the aluminium cables for connection

The AC-side terminals are suitable for connecting single-wire, round aluminium cables. Because of the formation of a non-conductive oxide layer due to the reaction of aluminium with air, the following points must be considered when connecting aluminium cables:

- the reduced rated currents for aluminium cables
- the connection conditions listed below

Always follow the cable manufacturer instructions when using aluminium cables.

When designing cable cross-sections, take local regulations into account.

### Connection conditions:

- 1 Carefully clean the oxide layer from the bare end of the cable by scraping it, e.g. with a knife

**IMPORTANT!** Do not use brushes, files or emery paper, as the aluminium particles get trapped and can be transferred to other conductors.

- 2 Once the oxide layer is removed, rub the end of the cable with a neutral grease, such as non-acidic and non-alkaline Vaseline

- 3 Immediately connect the cable end to the terminal

**IMPORTANT!** Repeat the procedure if the cable has been disconnected and is to be re-connected.

### AC terminals

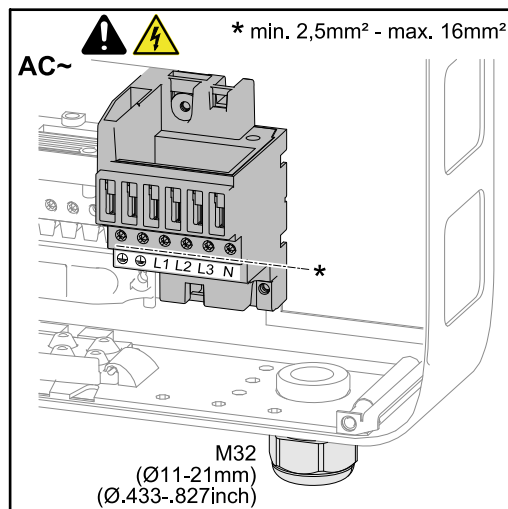

PE Ground conductor / earthing  
L1-L3 Phase conductor  
N Neutral conductor

Max. cross-section of each conductor cable:  
16 mm<sup>2</sup>

Min. cross-section of each conductor cable:  
in accordance with the fuse rating on the AC side, but at least 2.5 mm<sup>2</sup>

The AC cables can be connected to the AC terminals without ferrules.

**IMPORTANT!** When using ferrules for AC cables with a cross-section of 16 mm<sup>2</sup>, the ferrules must be crimped with a right-angled cross-section.

The use of ferrules with insulating collars is only permitted up to a max. cable cross-section of 10 mm<sup>2</sup>.

### Cross section of the AC cable

For a standard M32 metric screw joint with a reducer:  
Cable diameter from 7-15 mm

When using an M32 metric screw joint (reducer removed):  
cable diameter from 11-21 mm  
(with a cable diameter of less than 11 mm, the strain-relief force is reduced from 100 N to a maximum of 80 N)

With cable diameters greater than 21 mm, the M32 screw joint must be replaced by an M32 screw joint with a larger clamping area – item number: 42,0407,0780 – strain-relief device M32 x 1.5 KB 18–25.

**Connecting the inverter to the public grid (AC)**

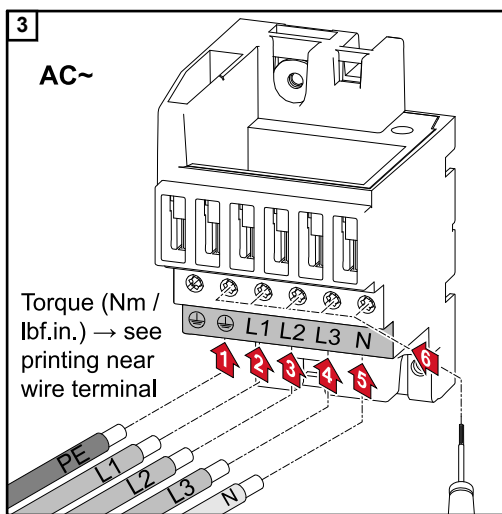
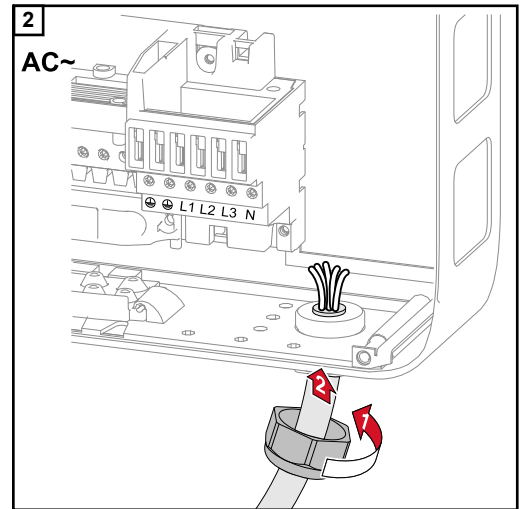
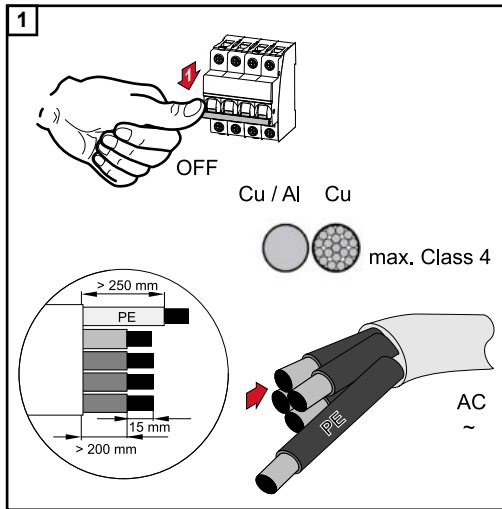

**Note!** Observe the torque values marked on the side underneath the terminals.

**Maximum fuse rating on alternating current side**

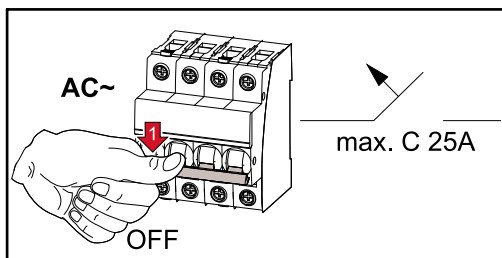

Inverter	Phase s	AC output	Maximum fuse rating	Recommended fuse rating
Fronius Symo 3.0-3-S / -M	3	3000 W	C 25 A	C 10 A
Fronius Symo 3.7-3-S / -M	3	3700 W	C 25 A	C 13 A
Fronius Symo 4.5-3-S / -M	3	4500 W	C 25 A	C 16 A
Fronius Symo 5.0-3-M	3	5000 W	C 25 A	C 16 A
Fronius Symo 6.0-3-M	3	6000 W	C 25 A	C 16 A
Fronius Symo 7.0-3-M	3	7000 W	C 25 A	C 20 A
Fronius Symo 8.2-3-M	3	8200 W	C 25 A	C 25 A

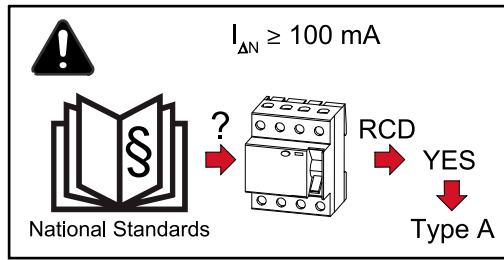

**Note!**

Local regulations, the electricity retailer or other factors may require a residual-current protective device in the AC connection lead.

A type A residual-current circuit breaker with a trip current of at least 100 mA is generally sufficient in this case. In particular cases, and depending on local factors, however, the type A residual-current circuit breaker may trip at the wrong time. For this reason, Fronius recommends that a residual-current circuit breaker that is suitable for frequency converters should be used.



# Notes regarding inverters with single and multiple MPP trackers

## Inverter with single MPP tracker

### Fronius Symo 3.0-3-S / 3.7-3-S / 4.5-3-S

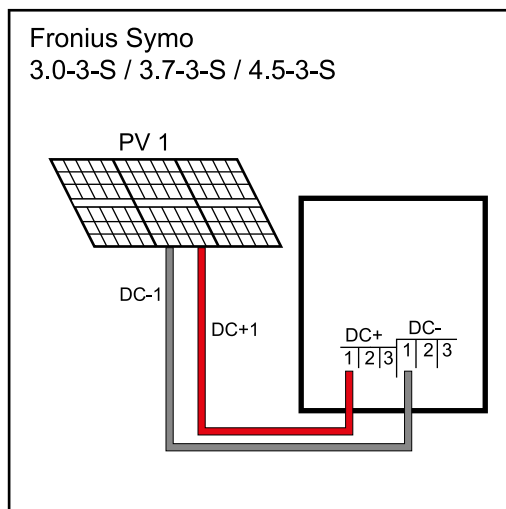

Connecting one solar module field to an inverter with a single MPP tracker

In the case of these inverters, there are 3 terminals available for each DC+ and DC-. The terminals are internally connected and are not fused. This means that a maximum of three strings can be connected directly to the inverter in parallel.

In this case, the solar modules must be able to carry at least the single reverse current (for 2 strings) or twice the reverse current (for 3 strings) (see data safety sheet for solar module).

Where there are more than three strings, an external combiner box with string fuses must be used. In this case, the strings must contain the same number of solar modules.

## Inverter with multiple MPP trackers

### Fronius Symo 3.0-3-M - 8.2-3-M

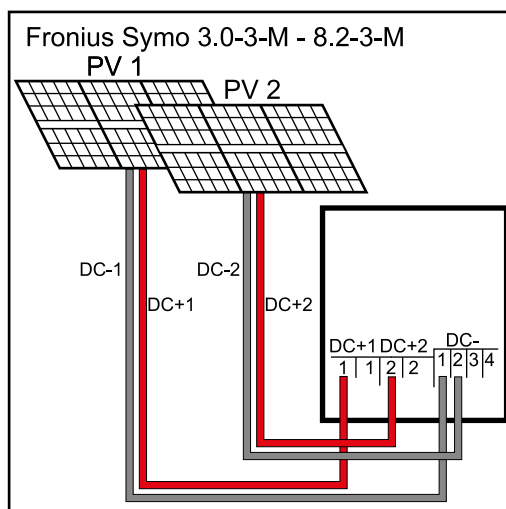

Connecting two solar module fields to an inverter with multiple MPP trackers

In the case of inverters with multiple MPP trackers, there are 2 independent DC inputs (MPP trackers) available. These can be connected to an unequal number of solar modules.

There are two terminals for DC+ available per MPP tracker. In total there are four terminals for DC-.

Connecting two to four strings in multiple MPP tracker mode:

divide the strings between the two MPP tracker inputs (DC+1/DC+2). The DC- terminals can be used however you wish, as they are internally connected.

When starting for the first time, set MPP TRACKER 2 to "ON" (this can also be done later in the Basic menu)

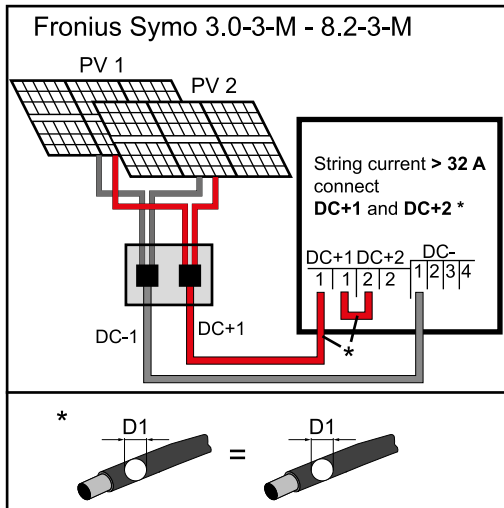

*Connecting multiple interconnected solar module fields to an inverter with multiple MPP trackers using one lead*

Single MPP tracker mode on an inverter with multiple MPP trackers:

If the strings are connected using a string combiner box and only one bus is used for connection to the inverter, the connection DC+1 (pin 2) and DC+2 (pin 1) must be jumpered.

The wire diameter of the DC connection lead and the jumpering must be the same. Jumpering of the DC terminal is not necessary, as these terminals are jumpered internally.

When starting for the first time, set MPP TRACKER 2 to "OFF" (this can also be done later in the Basic menu)

If the inverter with multiple MPP trackers is operated in single MPP tracker mode, the currents from the connected DC leads are divided evenly across both inputs.

# Connecting solar module strings to the inverter

## Safety

### **WARNING!**

#### **Danger due to incorrect operation and incorrectly performed work.**

This can result in serious injury and damage to property.

- ▶ Only qualified staff are authorised to commission your inverter and only within the scope of the respective technical regulations.
- ▶ Read the Installation and Operating Instructions before installing and commissioning the equipment.

### **WARNING!**

#### **Danger due to grid voltage and DC voltage from solar modules that are exposed to light.**

This may result in an electric shock.

- ▶ Ensure that both the AC side and the DC side of the inverter are de-energised before carrying out any connection work.
- ▶ Only an authorised electrical engineer is permitted to connect this equipment to the public grid.

### **WARNING!**

#### **Danger due to grid voltage and DC voltage from solar modules.**

This may result in an electric shock.

- ▶ The DC main switch is only to be used to de-energise the power stage set. The connection area is still live when the DC main switch is switched off.
- ▶ Ensure that the power stage set and connection area are disconnected from one another before carrying out any maintenance or service tasks.
- ▶ The power stage set, which is enclosed in a separate housing, must only be disconnected from the connection area when in a de-energized state.
- ▶ Maintenance and servicing in the power stage set of the inverter must only be carried out by Fronius-trained service technicians.

### **CAUTION!**

#### **Danger due to incorrectly tightened terminals.**

This may result in heat damage to the inverter, which may lead to fire.

- ▶ When connecting AC and DC cables, ensure that all the terminals are tightened to the specified torque.

### **CAUTION!**

#### **Danger due to overloading.**

This may result in damage to the inverter.

- ▶ Fronius Symo: The maximum amperage when connecting to a single DC terminal is 33 A.
- ▶ Fronius Eco: The maximum amperage when connecting to a single DC terminal is 15 A.
- ▶ Connect the DC+ and DC- cables to the DC+ and DC- terminals on the inverter, taking care to ensure that the polarity is correct.
- ▶ Observe the maximum DC input voltage.

**Note!** The solar modules connected to the inverter must comply with the IEC 61730 Class A standard.

**Note!** When photovoltaic modules are exposed to light, they supply current to the inverter.

### General comments regarding solar modules

To enable suitable solar modules to be chosen and to use the inverter as efficiently as possible, it is important to bear the following points in mind:

- If insolation is constant and the temperature is falling, the open circuit voltage of the solar modules will increase. The open circuit voltage must not exceed the maximum permissible system voltage. If the open circuit voltage exceeds the specified values, the inverter will be destroyed and no warranty claims will be entertained.
- The temperature coefficients on the solar modules data sheet must be observed.
- More exact values for dimensioning the solar modules can be provided by suitable calculation programs, like the Fronius Solar.configurator (which can be downloaded from <http://www.fronius.com>).

**Note!** Before connecting up the solar modules, check that the voltage for the solar modules specified by the manufacturer corresponds to the actual measured voltage.

### DC terminals

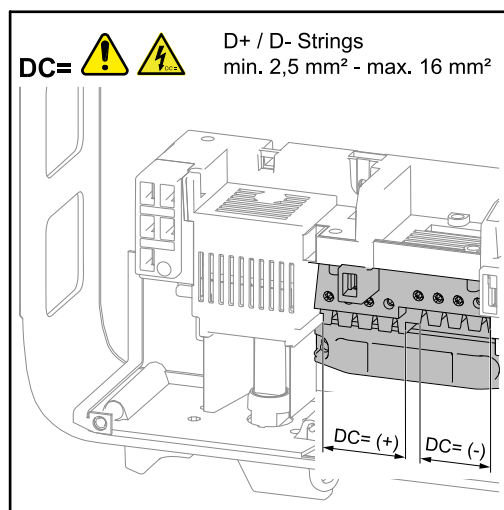

Cable cross section per DC cable: minimum 2.5 mm<sup>2</sup> - maximum 16 mm<sup>2</sup>

The DC cables can be connected to the DC terminals without ferrules.

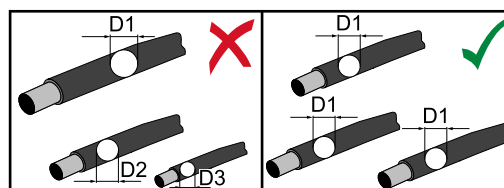

**Note!** To ensure effective strain relief of the solar module strings, only use cables with identical cross-sections.

**IMPORTANT!** When using ferrules for DC cables with a cross-section of 16 mm<sup>2</sup>, the ferrules must be crimped with a right-angled cross-section.

The use of ferrules with insulating collars is only permitted up to a max. cable cross-section of 10 mm<sup>2</sup>.

### Connecting aluminium cables

The DC-side terminals are suitable for connecting single-wire, round aluminium cables. Because of the formation of a non-conductive oxide layer due to the reaction of aluminium with air, the following points must be considered when connecting aluminium cables:

- the reduced rated currents for aluminium cables
- the connection conditions listed below

**Note!** Always follow the cable manufacturer instructions when using aluminium cables.

**Note!** When designing cable cross-sections, take local regulations into account.

#### Connection conditions:

- 1 Carefully clean the oxide layer from the bare end of the cable by scraping it, e.g. with a knife

**IMPORTANT!** Do not use brushes, files or emery paper, as the aluminium particles get trapped and can be transferred to other conductors.

- 2 Once the oxide layer is removed, rub the end of the cable with a neutral grease, such as non-acidic and non-alkaline Vaseline
- 3 Immediately connect the cable end to the terminal

**IMPORTANT!** Repeat the procedure if the cable has been disconnected and is to be re-connected.

#### Solar module strings - checking the polarity and voltage

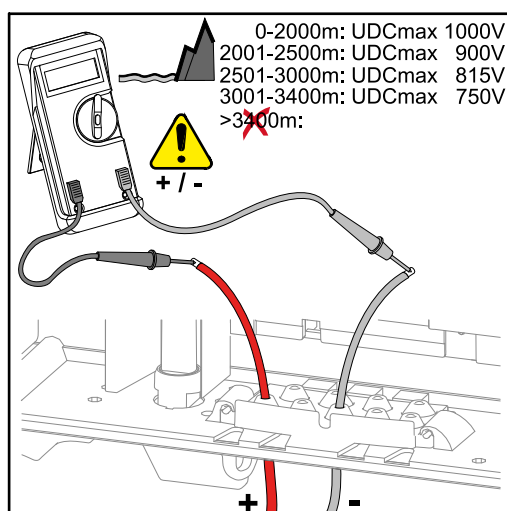

#### CAUTION!

#### Danger due to incorrect polarity and voltage.

This may result in damage to the inverter.

- ▶ Check the polarity and voltage of the solar module strings before making the connection. The voltage must not exceed the following values:
  - When installed between 0 and 2000 m above sea level: 1000 V
  - When installed between 2001 and 2500 m above sea level: 900 V
  - When installed between 2501 and 3000 m above sea level: 815 V
  - When installed between 3001 and 3400 m above sea level: 750 V

#### Connecting solar module strings to the inverter (DC)

**Note!** Only break out as many target break points as there are cables.

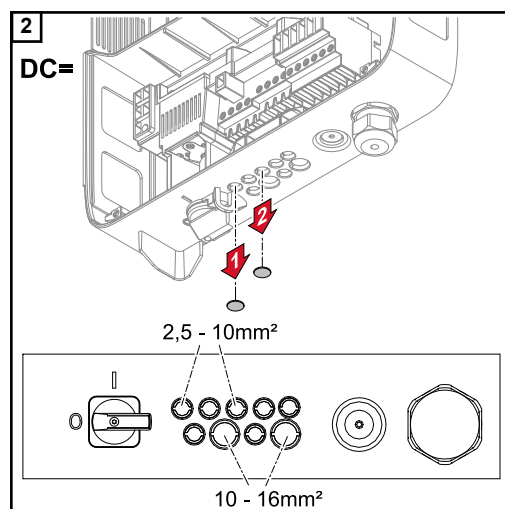
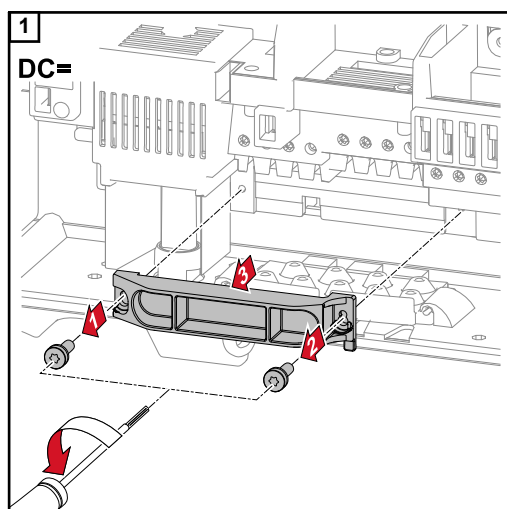

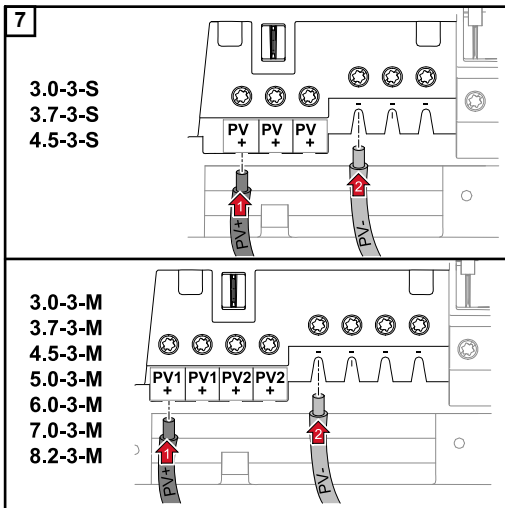
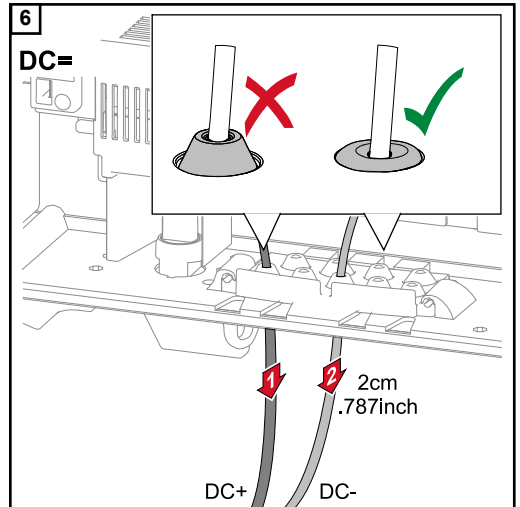
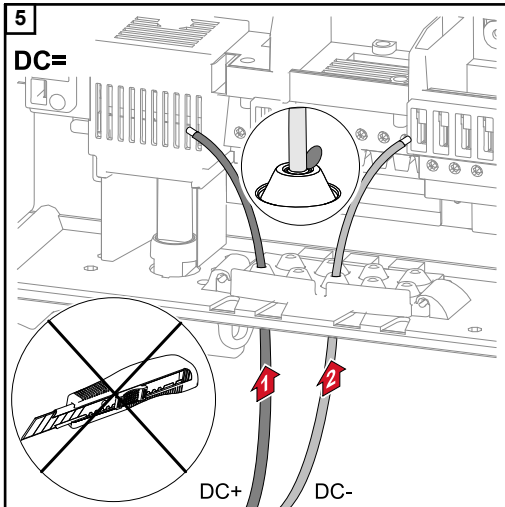
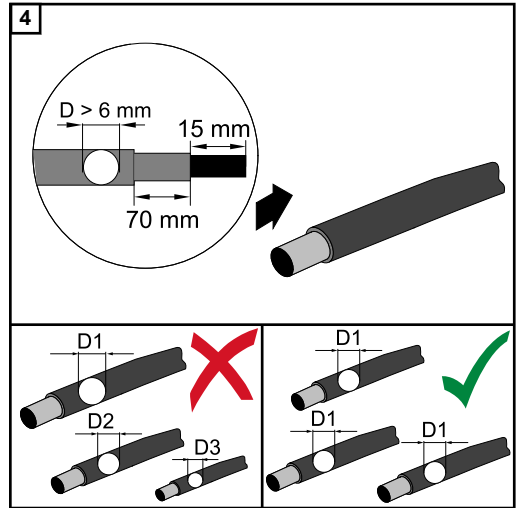
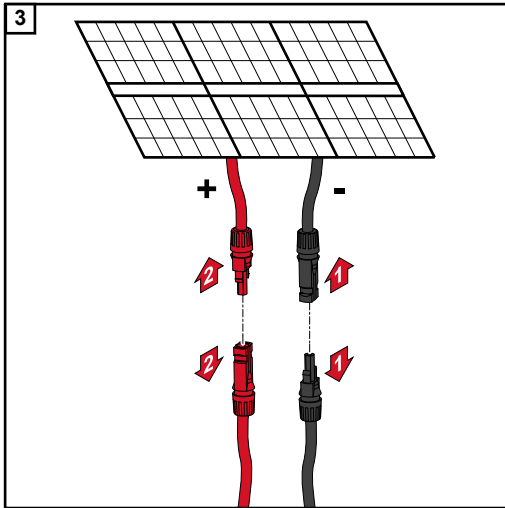

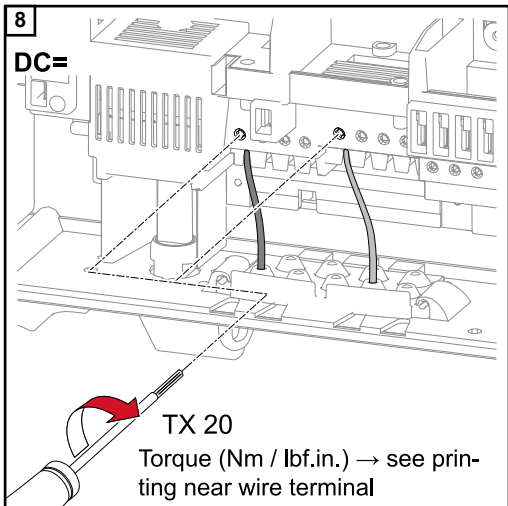

**Note!** Observe the torque values marked on the side underneath the terminals.

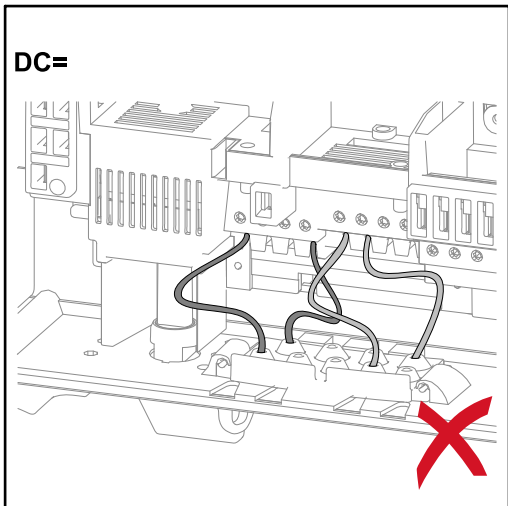
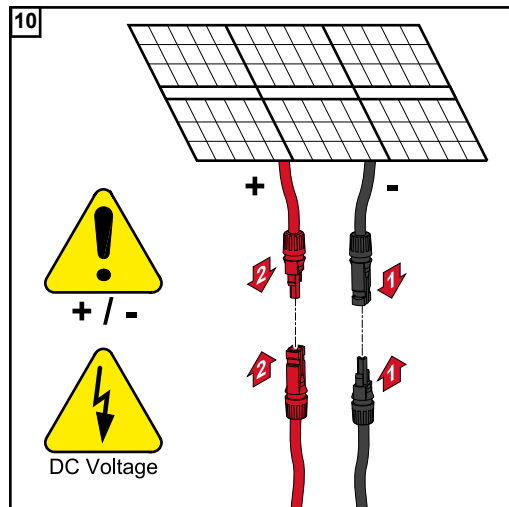
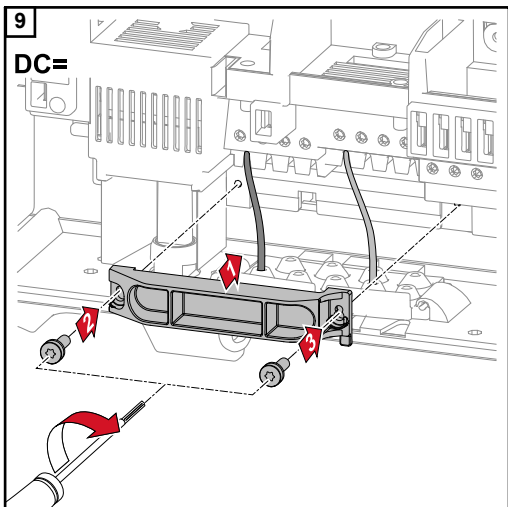

If DC cables are laid over the shaft of the DC main switch or across the connection block of the DC main switch, they may be damaged when the inverter is swung in or they may even prevent the inverter from being swung in.

**IMPORTANT!** Do not lay DC cables over the shaft of the DC main switch or across the connection block of the DC main switch.

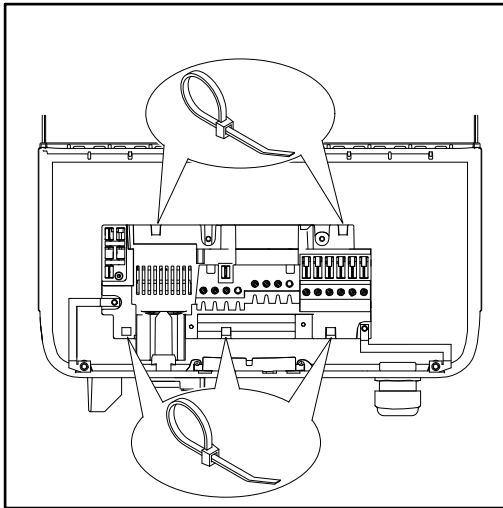

If overlength AC or DC cables are to be laid in loops in the connection area, attach the cables with cable ties to the eyelets provided on the top and bottom of the connection block.



# Data communication

## Routing data communication cables

**IMPORTANT!** Operating the inverter with one option card and two broken-out option card slots is not permitted. To cater for this eventuality, a suitable blanking cover (42,0405,2020) is available from Fronius as an option.

**IMPORTANT!** If data communication cables are wired into the inverter, observe the following points:

- Depending on the number and cross-section of the data communication cables that are being introduced, take the relevant blanking plugs out of the sealing insert and insert the data communication cables.
- The relevant blanking plugs must be inserted into the free openings on the sealing insert.

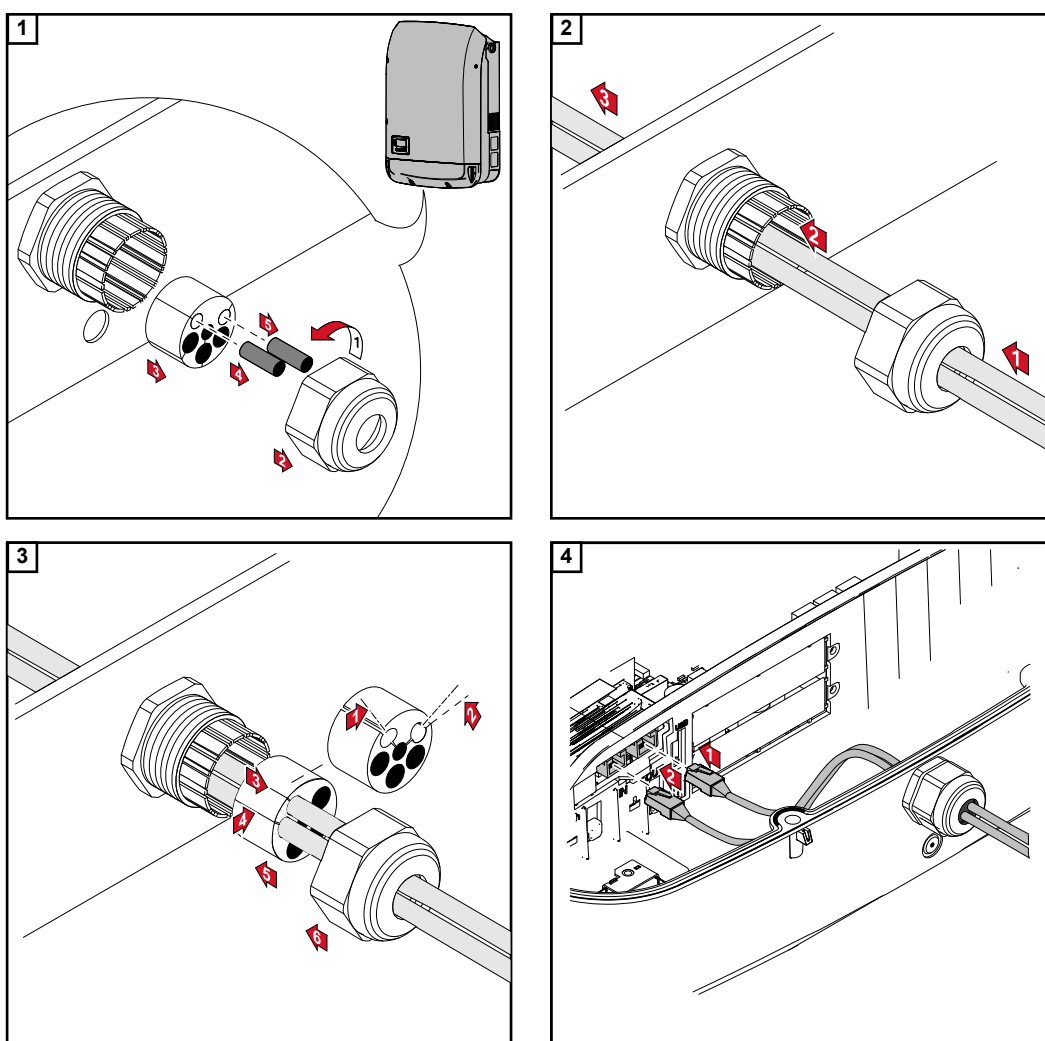

## Installing the Datamanager in the inverter



### WARNING!

**Danger of residual voltage from capacitors.**

This may result in an electric shock.

- Wait for the capacitors to discharge. The discharge time is five minutes.



## WARNING!

### Danger from inadequate ground conductor connection.

This can result in serious injury and damage to property.

- ▶ The housing screws provide a suitable ground conductor connection for earthing the housing and must NOT be replaced by any other screws that do not provide a reliable ground conductor connection.

**IMPORTANT!** Observe the ESD guidelines when handling option cards.

**IMPORTANT!** Only one Fronius Datamanager in master mode is permitted per Fronius Solar Net ring. Switch any other Fronius Datamanagers to slave mode or remove them. Seal off the unoccupied option card slot by replacing the cover (item number 42,0405,2094); alternatively, use an inverter without a Fronius Datamanager (light version).

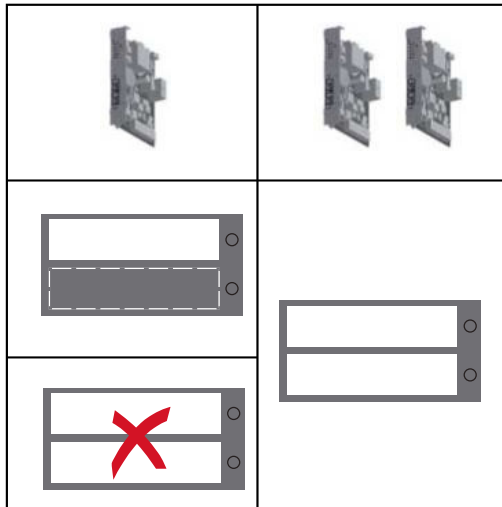

**IMPORTANT!** Only break out one opening for the PC board when installing a Datamanager in the inverter.

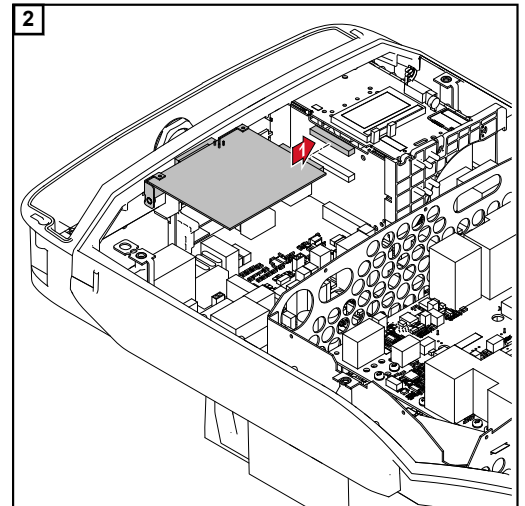
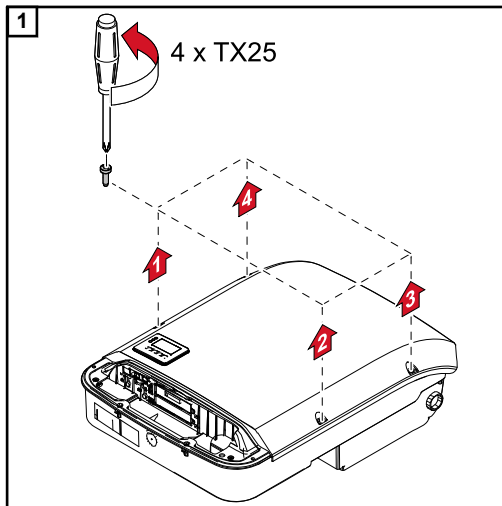

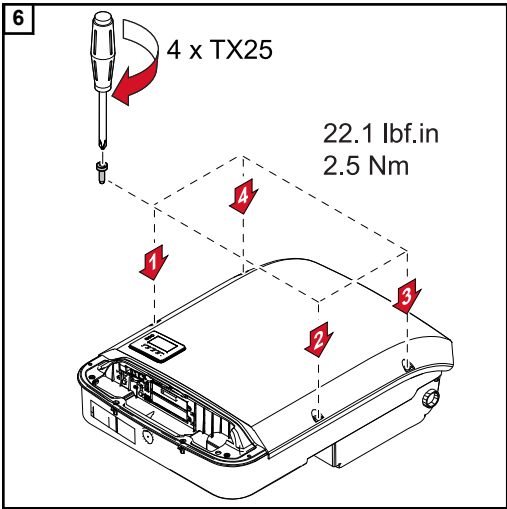
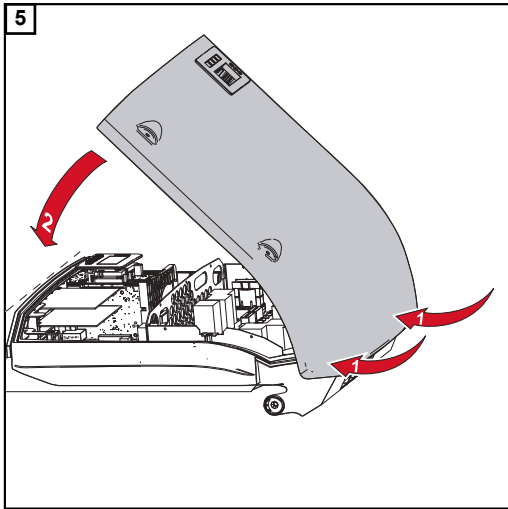
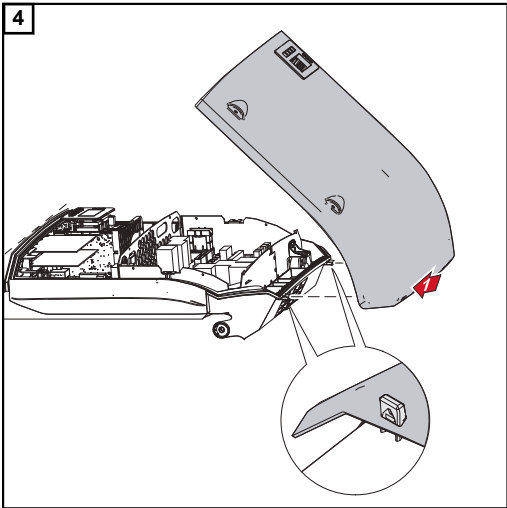
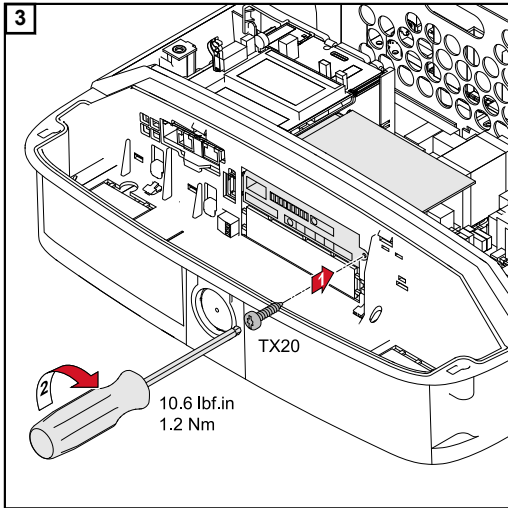

# Attaching the inverter to the mounting bracket

## Attaching the inverter to the mounting bracket

### **WARNING!**

#### **Danger from inadequate ground conductor connection.**

This can result in serious injury and damage to property.

- ▶ The housing screws provide a suitable ground conductor connection for grounding the housing and must NOT be replaced by any other screws that do not provide a reliable ground conductor connection.

The side sections of the housing lid are designed to function as holding and carrying handles.

**Note!** For safety reasons, the inverter is fitted with a latch that prevents the inverter from being swung into the mounting bracket unless the DC main switch is switched off.

- Never attach the inverter to the mounting bracket or swing it in unless the DC main switch is switched off.
- Never use force to attach the inverter or swing it in.

The fastening screws in the data communication area of the inverter are used for securing the inverter to the mounting bracket. Correctly tightened fastening screws are a prerequisite if proper contact is to be established between the inverter and mounting bracket.

### **CAUTION!**

#### **Danger due to incorrectly tightened fastening screws.**

This may result in arcs occurring when the inverter is in operation, which may lead to fire.

- ▶ Always use the specified torque when tightening the fastening screws.

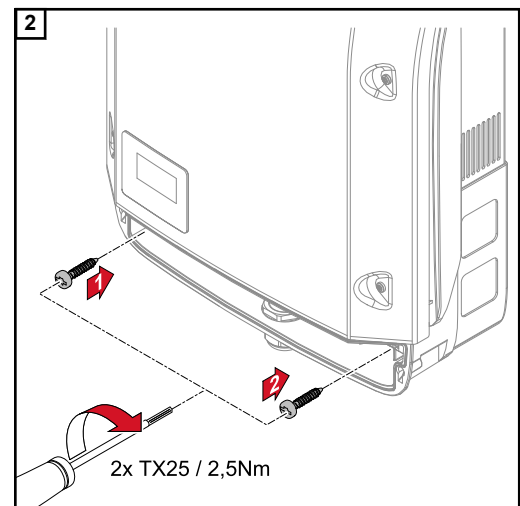
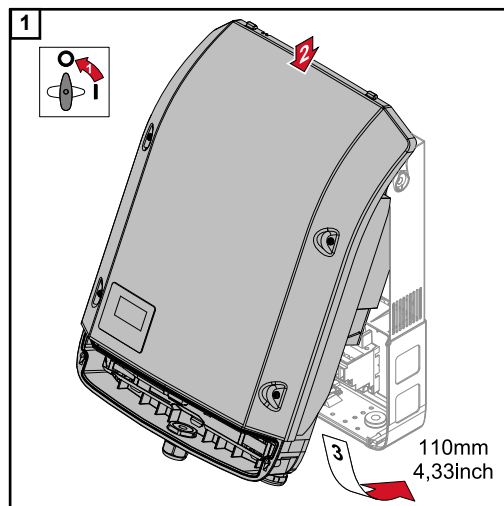

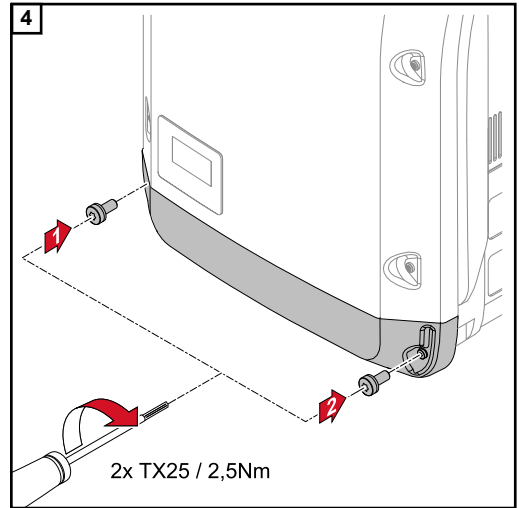
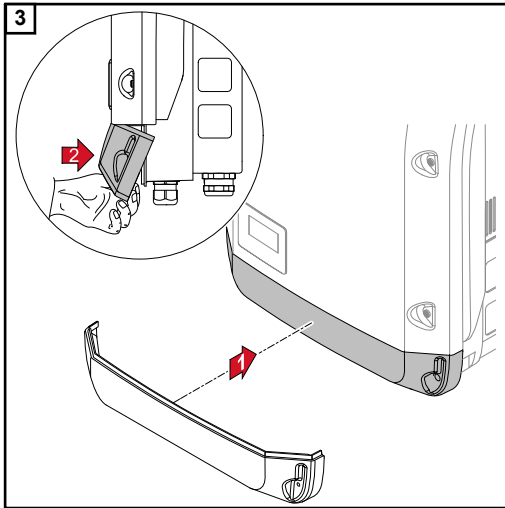

# Starting for the first time

## Starting the inverter for the first time

### **WARNING!**

#### **Danger due to incorrect operation and incorrectly performed work.**

This can result in serious injury and damage to property.

- ▶ Only qualified personnel are authorised to commission your inverter and only within the scope of the respective technical regulations.
- ▶ Read the Installation and Operating Instructions before installing and commissioning the equipment.

When starting the inverter for the first time, it is necessary to select various setup settings.

If setup is interrupted before it is complete, it can be restarted by means of an AC reset. An AC reset can be carried out by switching the automatic circuit breaker off and on again.

The country setup can only be set when using the inverter for the first time. If the country setup needs to be changed at a later date, please contact your Technical Support team.

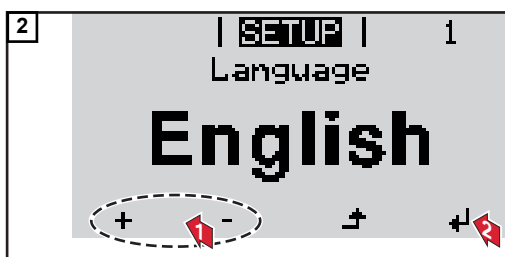
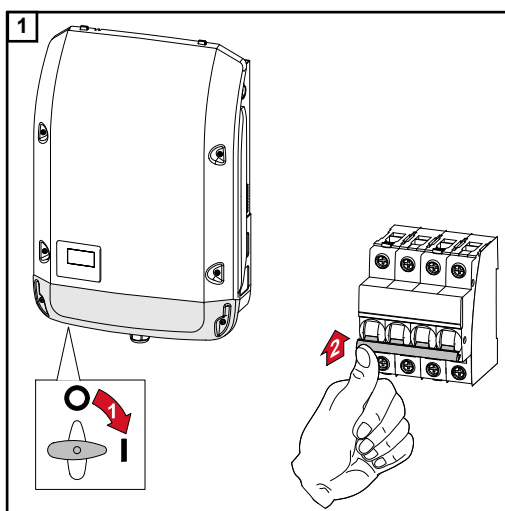

### \* Country setup examples

The available country setups may change during a software update. Therefore, the following list may not exactly match the display on the inverter.

50Hz	International 50 Hz	DE2P	Deutschland (> 4,6 kVA) - cosPhi(P) 0,9	IT6	Italia ≤ 11,08 kVA 2019
60Hz	International 60 Hz			IT7	Italia > 11,08 kVA 2019
AT1E	Österreich cosphi = 1	DE2U	Deutschland (> 4,6 kVA) - Q(U)	JO98	Jordan G98
AT2E	Österreich cosphi P 0,9			JO99	Jordan G99
AT3E	Österreich: Q(U)	DKA1	West Denmark - 125kW	LK	Sri Lanka
AU1	Australia AUS1 - AS/ NZS4777.2	DKA2	East Denmark - 125kW	MG50	Microgrid 50 Hz
AU2	Australia AUS2 - VIC	DU1	Dubai < 10 kW	MG60	Microgrid 60 Hz
AU3	Australia AUS3 - NSW Ausgrid	DU2	Dubai 10 kW - 400 kW	NI98	Northern Ireland G98
AU4	Australia AUS4 - QLD	EE	Estonia	NI99	Northern Ireland G99
AU5	Australia AUS5 - SA	ES	España	NL	Nederland
AU6	Australia AUS6 - WA - WP	ESOS	Territorios españoles en el extranjero (Spanish Over- seas Islands)	NO	Norge
AU7	Australia AUS7 - WA - HP	EULV	EU - low voltage	NZ	New Zealand
BE	Belgique / België	EUMV	EU - medium voltage	PF1	Polynésie française (French Polynesia)
BR2	Brasil: ≤ 6 kVA	FI	Finland	PL	Poland
BR3	Brasil: > 6 kVA	FR	France	PT	Portugal
CH	Schweiz / Suisse / Svizzera / Svizra	FROS	Territoire d'Outre-Mer (French Overseas Islands)	RO	România
CL	Chile	G98	Great Britain GB - G98	SA	Saudi Arabia
CY	Κύπρος / Kibris / Cyprus	GB	Great Britain	SE	Sverige
CZ	Česko	GR	Ελλάδα	SI	Slovenija
DE1F	Deutschland (≤ 4,6 kVA) - konst. cosPhi(1)	HR	Hrvatska	SK	Slovensko
DE1P	Deutschland (≤ 4,6 kVA) - cosPhi(P) 0,95	HU	Magyarország	TH M	Thailand MEA
DE2F	Deutschland (> 4,6 kVA) - konst. cosPhi(1)	IE	Éire / Ireland	TH P	Thailand PEA
		IL	إسرائيل / ישראל / Israel	TR	Türkiye
		IN	India	UA	Україна
				ZA	South Africa / Suid-Afrika

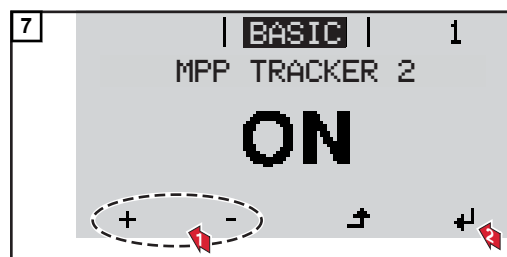
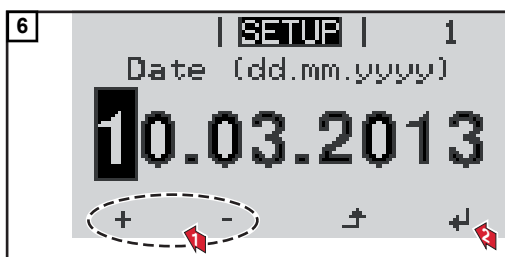
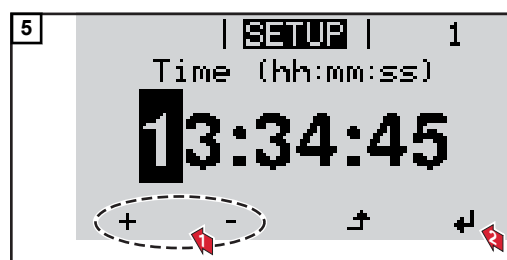

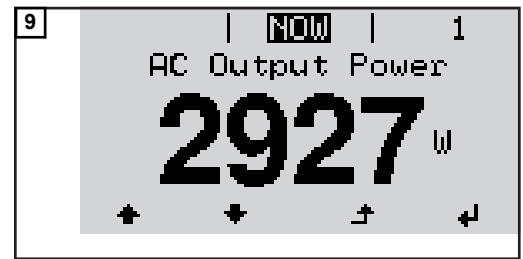
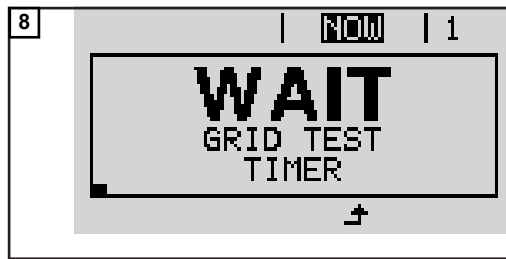



# Notes regarding software updates

## Notes regarding software updates

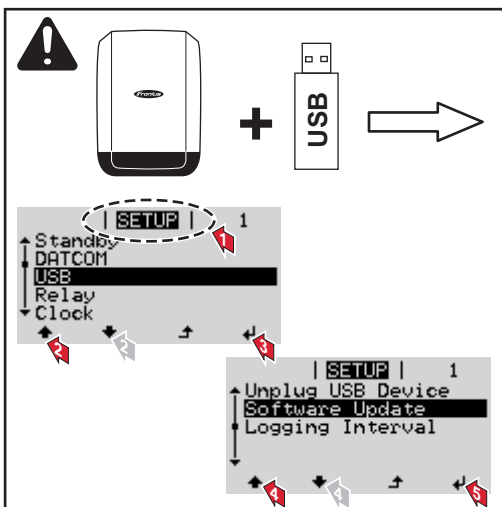

If the inverter is supplied with a USB flash drive, the inverter software must be updated as soon as the inverter has been commissioned:

- 1 Plug the USB flash drive into the data communication area of the inverter
- 2 Open the Setup menu
- 3 Select the "USB" menu item
- 4 Select "Software Update"
- 5 Update the software

# USB Stick as a Data Logger and for Updating Inverter Software

## USB flash drive as a datalogger

If a USB flash drive is connected to the USB A socket it can function as a datalogger for an inverter.

The logging data stored on the USB flash drive can be viewed at any time in third-party programmes (e.g Microsoft® Excel) using the CSV file logged at the same time.

Older versions of Excel (before Excel 2007) are limited to a maximum of 65,536 rows.

## Data on the USB flash drive

If the USB flash drive is being used as a data logger, three files will be created automatically:

- FRONIUS.sys system file:  
This file stores information from the inverter that is irrelevant to the customer. The file must not be deleted separately. Only delete all of the files (sys, fld, csv) at one time.

- DALO.fld log file:  
A log file for reading the data in the Fronius Solar.access software.

Further details on the Fronius Solar.access software can be found in the "DATCOM Details" operating instructions at <http://www.fronius.com>

- DATA.csv log file:  
A log file for reading the data in a spreadsheet program (e.g.: Microsoft® Excel)

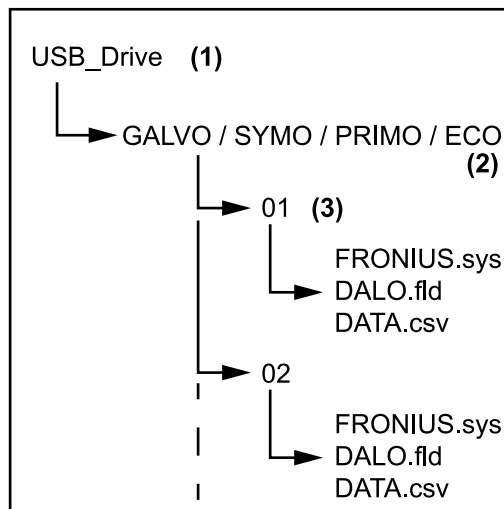

- (1) USB root directory
- (2) Fronius inverters (Fronius Galvo, Fronius Symo, Fronius Primo or Fronius Eco)
- (3) Inverter number - can be set in the Setup menu under DATCOM

If there are several inverters with the same inverter number, the three files will be saved in the same folder. A digit is added to the file name as a suffix (e.g.: DALO\_02.fld)

Data structure on the USB flash drive

Structure of the CSV file:

	(1)	(2)	(3)	(4)	(5)	(6)	(7)	
	A	B	C	D	E	F	G	H
1	SerialNr.:123456789987456321'							
2	Date	Time	Inverter No.	Device Type	Periode [s]	Energy [Ws]	Energy L[Var]	Energy C[Var]
3	30.03.2013	17:15:19	1	247				
4	30.03.2013	17:15:19	1	247				
5	30.03.2013	17:15:19	1	247				
6	30.03.2013	17:15:20	1	247				

	(8)	(9)									
	I	J	K	L	M	N	O	P	Q	R	S
	Uac L1 [V]	Uac L2 [V]	Uac L3 [V]	Iac L1 [A]	Iac L2 [A]	Iac L3 [A]	Udc S1[V]	Idc S1[A]	Description		
									Display Information		
									V0.1.5 Build 0		
									28.03.2013 23:59:49 Info 017, Counter 0092		
									Logging Start		

- (1) ID
- (2) Inverter no.
- (3) Inverter type (DATCOM code)
- (4) Logging interval in seconds
- (5) Energy in watts per second, relative to the logging interval
- (6) Inductive reactive power
- (7) Capacitive reactive power
- (8) Average values during the logging interval (AC voltage, AC current, DC voltage, DC current)
- (9) Additional information

### Data volume and storage capacity

A USB flash drive with a storage capacity of 1 GB can record logging data for roughly seven years at a logging interval of five minutes.

#### CSV file

CSV files can only store 65,535 lines (data records) (up to Microsoft® Excel 2007; there is no restriction from this version onwards).

At a five-minute logging interval, the 65,535 lines will be written within approximately seven months (CSV data size of approx. 8 MB).

In order to avoid data loss, the CSV file should be backed up to a PC and deleted from the USB flash drive within this seven-month period. If the logging interval is set to a longer period, this time frame will be increased accordingly.

#### FLD file

The FLD file should not be larger than 16 MB. This will provide enough storage capacity for approximately six years at a logging interval of five minutes.

If the file exceeds the 16 MB limit, it should be backed up to a PC and all of the data on the USB flash drive should be deleted.

After backing up and removing the data, the USB flash drive can be reconnected immediately to resume recording the logging data without any further steps being required.

**Note!** Using a full USB flash drive can lead to data loss or data being overwritten. When using USB flash drives, always ensure that there is sufficient storage capacity on the flash drive.

## NOTE!

### Risk of USB flash drive becoming full.

This may result in data being lost or overwritten.

- ▶ When using USB flash drives, always ensure that there is sufficient storage capacity on the flash drive.
- 

### Buffer memory

If the USB stick is unplugged (e.g. for data backup purposes), the logging data is written to a buffer memory in the inverter.

As soon as the USB stick is plugged in again, the data is copied automatically from the buffer memory to the stick.

The buffer memory can store a maximum of six logging points. Data is only logged while the inverter is running (output greater than 0 W). The logging interval is permanently set at 30 minutes. Data can be recorded on the buffer memory for a three-hour time period as a result.

When the buffer memory is full, the oldest data in the memory will be overwritten by the next batch of data.

**IMPORTANT!** The buffer memory requires a permanent power supply.

If there is a power failure while the inverter is in operation, all the data in the buffer memory will be lost. To avoid losing data during the night, the automatic night switch-off facility must be deactivated (switch the "Night Mode" setup parameter to ON - see the Datamanager 2.0 Operating Instructions, section "Setting and displaying the menu items", "Viewing and adjusting parameters in the DATCOM menu item").

On the Fronius Eco or Fronius Symo 15.0-3 208, the buffer memory also functions with just a DC supply.

---

### Suitable USB flash drives

Due to the variety of USB flash drives available on the market, it cannot be guaranteed that every USB flash drive will be detected by the inverter.

Fronius recommends that only certified, industry-grade USB flash drives are used (look out for the USB-IF logo).

The inverter supports USB flash drives with the following file systems:

- FAT12
- FAT16
- FAT32

Fronius recommends that the USB flash drive employed should only be used for recording logging data or updating the inverter software. The USB flash drives should not contain any other data.

USB symbol on the inverter display, e.g. in display mode 'NOW':

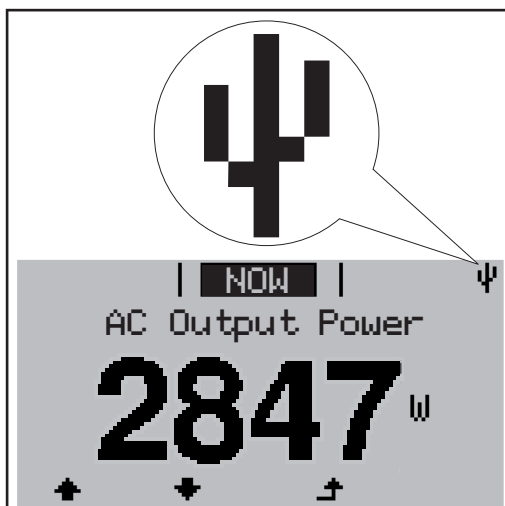

If the inverter detects a USB flash drive, the USB symbol will appear in the top right corner of the display.

When inserting a USB flash drive, check whether the USB symbol is displayed (it may also flash).

**Note!** Please note for outdoor applications that conventional USB flash drives are often only guaranteed to work within a restricted temperature range. For outdoor applications ensure that the USB flash drive also functions, for example, at low temperatures.

**USB stick for updating the inverter software**

With the help of the USB stick, end customers can also update the inverter software via the USB item on the SETUP menu: the update file is first saved to the USB stick, from where it is then transferred to the inverter. The update file must be saved in the root directory on the USB stick.

**Removing the USB flash drive**

Safety instruction concerning the removal of a USB flash drive:

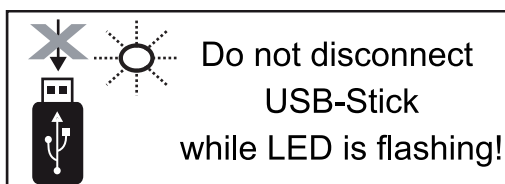

**IMPORTANT!** To avoid any loss of data, a USB flash drive may only be removed if the following conditions are met:

- Only remove a USB flash drive via the 'Safely remove USB / HW' item on the SETUP menu
- The 'Data transmission' LED has stopped flashing or comes on steady.

# Notes regarding maintenance

---

## Maintenance

**Note!** When installed outdoors in a horizontal position: once a year, check that all screw joints are tight!

Maintenance and servicing may only be carried out by Fronius-trained service technicians.

---

## Cleaning

Clean the inverter as required with a damp cloth.

Do not use cleaning agents, abrasives solvents or similar to clean the inverter.

# Australian cable protection hoses

## Tightly sealing the protection hoses

Ensure that the cable protection hoses are tightly sealed.

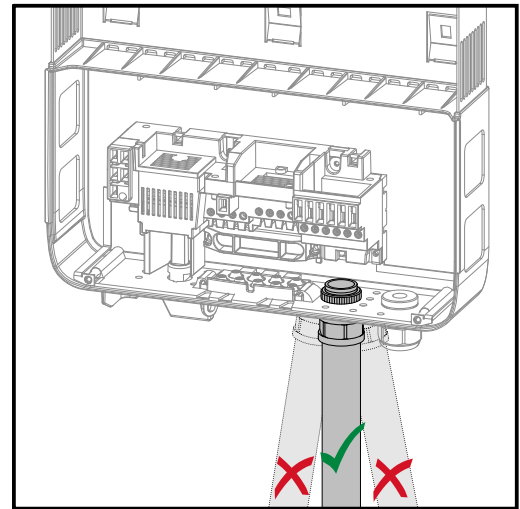
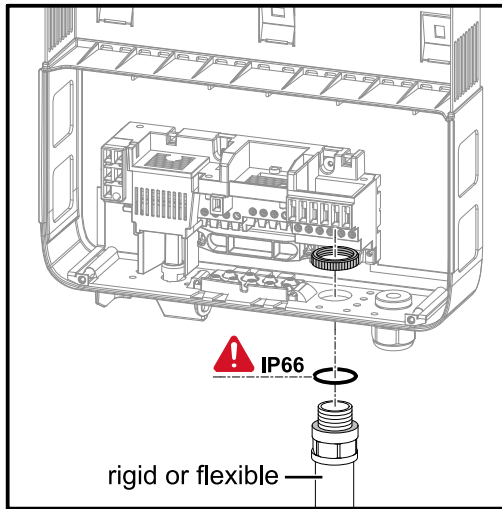

## Seal conduits

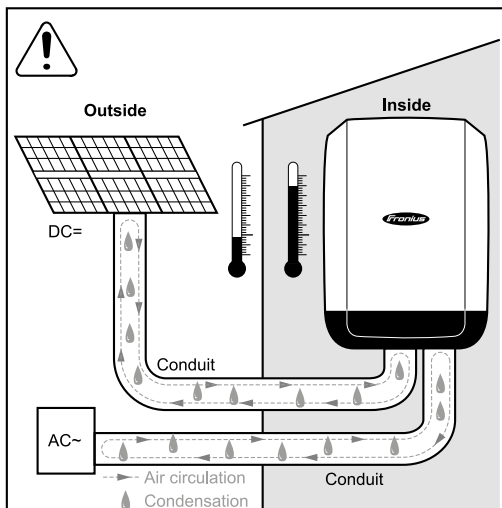

### NOTE!

Condensation within the conduits can damage the inverter or components of the photovoltaic systems.

To avoid undesirable air circulation and condensation in the conduits:

- ▶ Seal all conduits being used with a permanently elastic sealant
- ▶ Seal every incoming and outgoing conduit
- ▶ Seal both conduit ends.

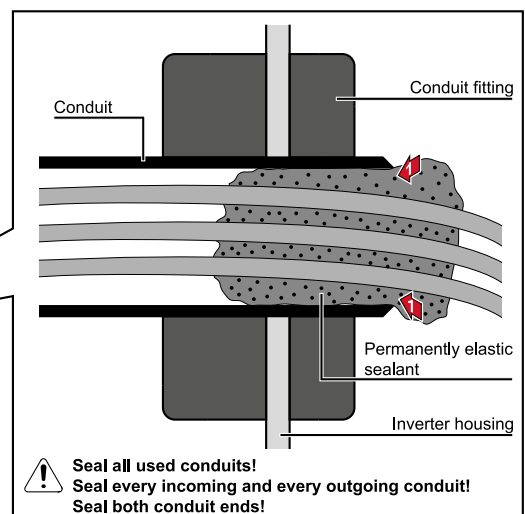
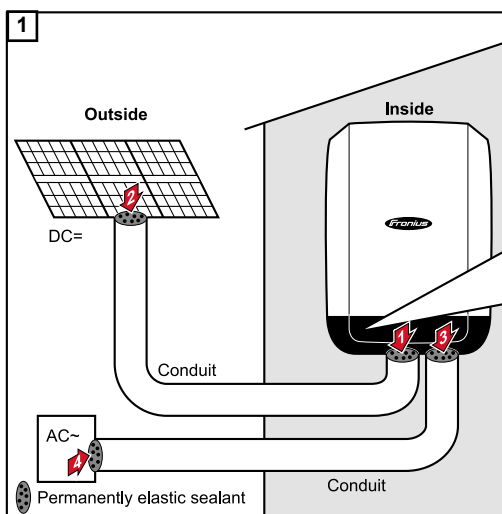

Seal all used conduits!  
Seal every incoming and every outgoing conduit!  
Seal both conduit ends!

# Serial Number Sticker for Customer Use

## Serial number sticker for customer use

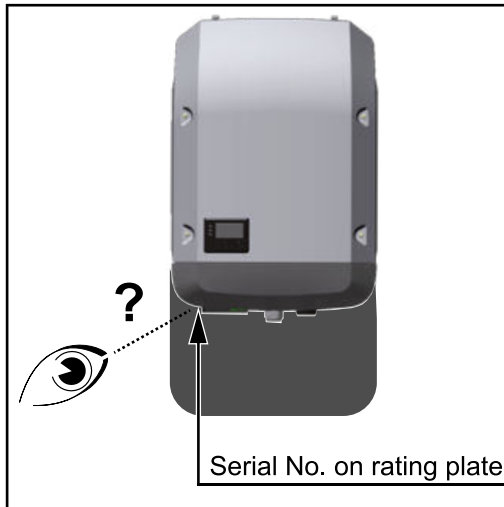

The serial number of the inverter is located on the rating plate on the bottom of the inverter.

Depending on the installation position of the inverter, the serial number can be difficult to access or read, e.g. if the inverter has been installed in a dark or shaded area.

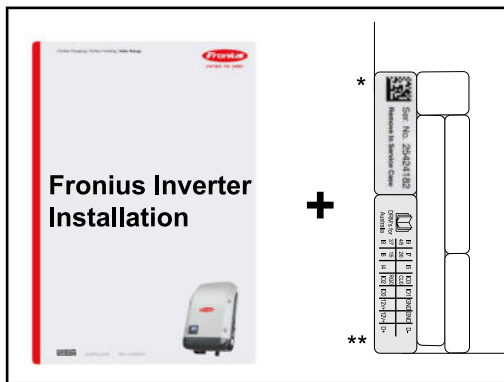

Two serial number stickers are enclosed with the inverter's installation instructions:

- \* 57 x 20 mm
- \*\* 67 x 20 mm

These can be affixed by the customer in a visible location of his choosing, e.g. on the front of the inverter or on the Operating Instructions.

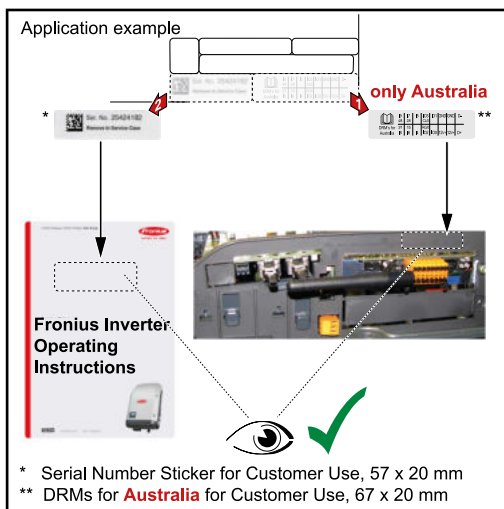

Application example:

Serial number sticker on the Operating Instructions or on the front of the inverter

For Australia only:

Affix the DRM Australia sticker in the Datamanager area.









**FRONIUS INTERNATIONAL GMBH**

Froniusstraße 1  
A-4643 Pettenbach  
AUSTRIA  
contact@fronius.com  
**www.fronius.com**

Under **www.fronius.com/contact** you will find the addresses  
of all Fronius Sales & Service Partners and locations.



Find your  
spareparts online



spareparts.fronius.com